

SMART



DROMEAS
OFFICE FURNITURE

SMART.

GR. μ μ !
μ μ Synchro μ
5 μ anti-panic .
μ μ μ
μ μ
μ - μ μ

EN. Simple and elegant seat!
It has a Synchro mechanism for a comfortable and synchronized seat - backrest motion with a stabilization system on 5 positions and anti-panic system.
It offers support for the lumbar region of each user, by adjusting a lever located on the back side of the backrest.
The armrests are adjustable in height and their surface can be moved towards the front or the back and rotate according to the needs of the user.

DE. Einfacher and stylvoller Bürostuhl!
Er verfügt über einen Synchron-Mechanismus für eine komfortable und synchronisierte Sitz- Rückenbewegung, mit Stabilisierungssystem in 5 Positionen und ein Anti-Panik System.
Er bietet eine Lordosenstütze für jeden Benutzer, durch die regulierung eines Schalters, der sich hinter dem Rücken befindet.
Die Armlehnen sind Höhenverstellbar und ihre Fläche vorne - hinten und ringserum dem Benutzer entsprechend.

FR. Siège simple et élégant!
il dispose un mécanisme synchro pour un mouvement de dossier confortable et synchronisé avec un système de stabilisation en 5 positions et un système anti-panique.
Il offre un soutien pour la région lombaire de chaque utilisateur, en réglant un levier situé sur l'arrière du dossier.
Les accoudoirs sont réglables en hauteur et leur surface est réglable en avant et en arrière et de manière rotative selon les besoins de l'utilisateur.



ΠΙΣΤΟΠΟΙΗΤΙΚΑ - CERTIFICATES
<https://www.dromeas.com/en/company/total-quality-management/certificates.html>



Smart μ

μ

Chair of the Smart series with a mesh back for modern aesthetics and convenient movement.

Bürodrehstuhl Smart mit Netzrücken für moderne Ästhetik und komfortablen Bewegungen.

Fauteuil de bureau SMART avec dossier en résille, ce qui garantit l'esthétique moderne et le grand confort des mouvements de chaque utilisateur.

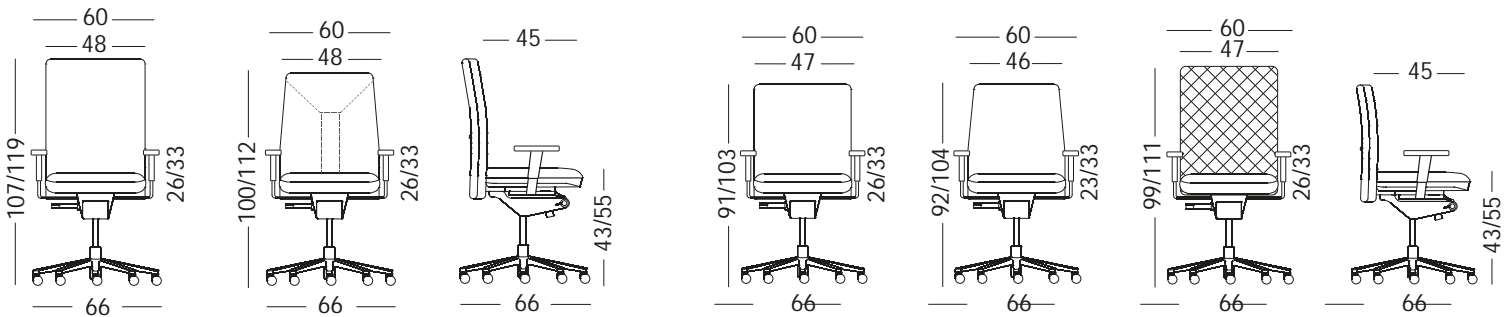

können die Spezifikationen (Design, Abmessungen, Oberflächen) ohne Ankündigung geändert werden.
Note: En raison de notre politique de développement et de l'amélioration continu de nos produits, nous nous réservons le droit de modifier les spécifications (design, dimensions, finitions) sans préavis.

ΠΙΣΤΟΠΟΙΗΤΙΚΑ - CERTIFICATES

ΒΡΑΒΕΙΑ - AWARDS



ΕΡΓΟΣΤΑΣΙΟ: . . . 62 121, . . . 23210 99220 F. 23210 99270 801 11 96000
PLANT: Industrial Area of Serres, 62 121, Serres, Greece . +30 23210 99220 F. +30 23210 99270
www.dromeas.gr e-mail: dromeas@dromeas.gr
ΑΘΗΝΑ: . . . 324 , . . . 210 6835250
ΘΕΣΣΑΛΟΝΙΚΗ: . . . μ 112 . 2310 311601
DROMEAS BG - BXB: 1618 Sofia, blvd.Bulgaria 110 ground floor T.+359 2 489 97 20
F.+359 2 489 97 21 www.dromeas.bg e-mail: office@dromeas.bg
DROMEAS BRUSSELS - BXB: Schaarbeeklei 605, 1800 Vilvoorde, Brussels - Belgium |
T. +32 -2-7510825 e-mail: info@dromeas.be



DROMEAS
OFFICE FURNITURE